

MRC1402



MATERIALS: The recycling station frame is made using recycled aluminum. Sustainable components such as HDPE plastic, high density paper composite (HDPC) or Steel are used for the sides and door panels. Two- 23 gallon commercial grade plastic liners and a stainless steel top are provided.

FINISH: All steel components are protected with E-Coat rust proofing. The Maglin Powdercoat System provides a durable finish on all metal surfaces.

INSTALLATION: The recycling station is delivered pre-assembled. Holes (0.5") are provided in each mounting foot for securing to base.

TO SPECIFY: Select MRC1402
Choose:

- Side/Door panels
 - HDPC
 - MRC1402-PCC (Charcoal)
 - MRC1402-PCS (Sandstone)
 - HDPE Plastic
 - MRC1402-PGY (Grey)
 - MRC1402-PBK (Black)
 - MRC1402-PBN (Brown)
- Steel
 - MRC1402-MS
- Powdercoat color
- Faceplate colour (Black or Green)

OPTIONS:

- Vinyl Graphics

*Vinyl graphics not recommended on Fine Textured powdercoat.

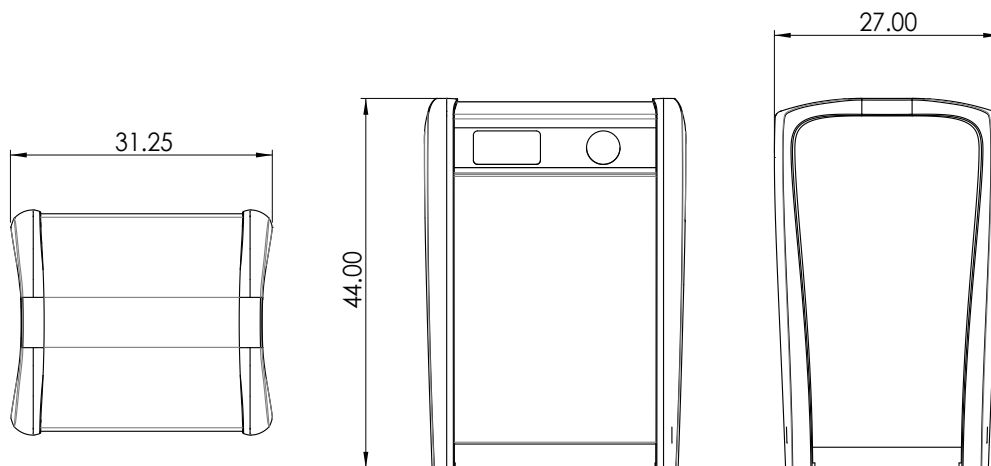

DIMENSIONS:
 Height: 44" (111.8cm)
 Weight: 110lbs (49.9kg)
 Liner Capacity: 2 x 23 Gallons
 2 x 87 Litres



MAGLIN™
Site Furniture

- Details and specifications may vary due to continuing improvements of our products.
 - All drawings, specifications, design and details on this page remain the property of Maglin Site Furniture Inc. and may not be used without Maglin authorization.

PRODUCT & PRICING INFO

 303.398.7040 STREET-SCAPES.COM