

1050 SERIES

MLP1050-PC



MATERIALS: The planter frame is constructed from formed steel and the sides employ 1/2" HDPC. A galvanized liner is included.

FINISH: All steel components are protected with E-Coat rust proofing. The Maglin Powdercoat System provides a durable finish on all metal surfaces.

INSTALLATION: The planter is delivered pre-assembled. The base has 9/16" holes for anchoring.

TO SPECIFY: Select MLP1050-PC
Choose:
- Powdercoat Color
- HDPC Color
(Charcoal, Sandstone)

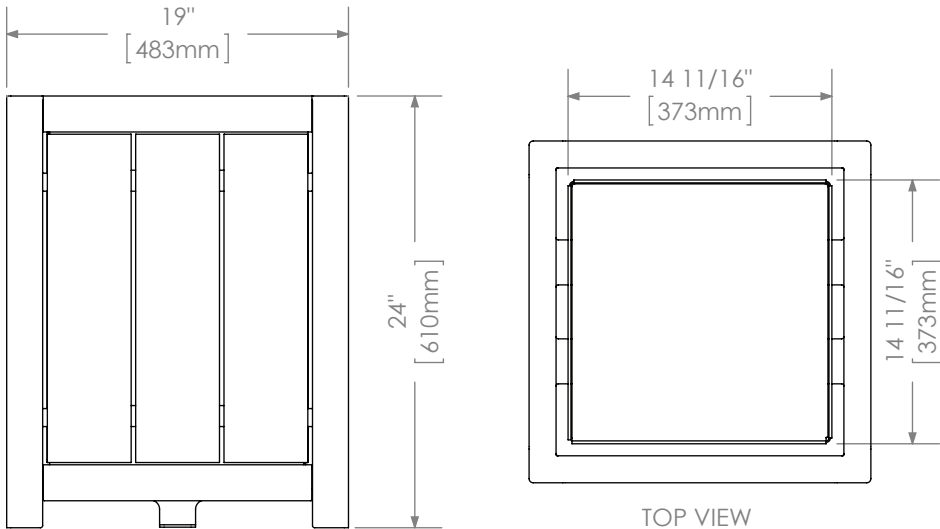

DIMENSIONS:
Height: 24" (61.0cm)
Length: 19" (48.3cm)
Depth: 19" (48.3cm)
Weight: 67.92lbs (30.8kg)



MAGLIN™
Site Furniture

- Details and specifications may vary due to continuing improvements of our products.
- All drawings, specifications, design and details on this page remain the property of Maglin Site Furniture Inc. and may not be used without Maglin authorization.

PRODUCT & PRICING INFO
STREETSCAPES
303.398.7040 STREET-SCAPES.COM