

TONIK™

JUX™ Dining Chair

A stretched, continuous shape folded and flared into being, JUX is an elegant interpretation of bar and dining sets. The collection is smooth and sculptural, while always conveying strength and durability for a range of environments. Deceptively simple at first glance, the JUX collection contains great complexity.

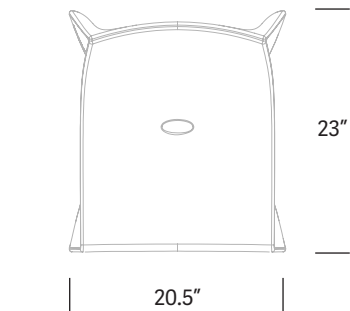
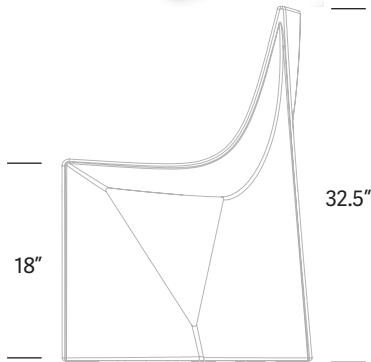

| Model # | Height | Width | Depth | Weight |
|---------|--------|-------|-------|--------|
| JX11 | 32.5" | 20.5" | 23" | 19 lbs |

Material

One-piece, rotationally molded, specially formulated, high-impact polyethylene with ultraviolet light stabilizers (to reduce fading). The commercial-grade polyethylene material is also FDA-approved, making it ideal for restaurants, food courts and entertainment facilities. Chemically resistant to bleach, salt solution and chlorine solution. Premium TruColor™ material is fully compounded for superior color and quality assurance. Enhanced UV resistant formulation suitable for both indoor and outdoor use.

Environmental Test Standards

GREENGUARD and GREENGUARD Gold Certified by UL Environment. Product certified for low chemical emissions to UL 2818. UL.COM/GG.

Performance Test Standards

Product tested to 500 lbs static load.

Assembly

None Required

Warranty

5 year limited replacement warranty.

Maintenance

For routine and regular cleaning maintenance, Tonik recommends the use of Simple Green® or an equivalent cleaning product. For the deep-scrub cleaning of tougher stains, marks and debris, we recommend the use of Clorox® Clean-Up® Cleaner + Bleach or an equivalent cleaning solution.

Color

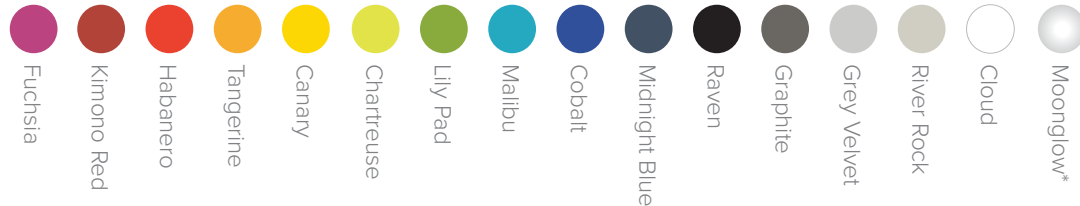

PRODUCT & PRICING INFO

STREETSCAPES
303.398.7040 STREET-SCAPES.COM

*Available in Moonglow, but not Illuminated.